



LOW VOLTAGE RESS LI-ION BATTERY USERS GUIDE

End User Documentation

Rev 1.1

Oct-10-2024



DOCUMENT NOTICE: The information contained in this manual is the property of Hengyang Rich power Co., Ltd. ("RITAR") and is subject to change without notice. RITAR reserves the right to make changes in the design of its products

or components as progress in engineering and manufacturing may warrant. It is the customer's responsibility to satisfy itself as to whether the information contained herein is adequate and sufficient for a user's particular use. It is the further responsibility of each user to ensure that all applications of RITAR's products are appropriate and safe based on conditions anticipated or encountered during use. This document does not create any additional obligation for RITAR and does not constitute additional warranties and representations.



WARNING: Explosion, Electrocution, Or Fire Hazard

- ☑ A battery can present a risk of electric shock, burns from high short circuit current, fire, or explosion.
- ☑ Observe proper precautions.
- ☑ Ensure the cables are properly sized.
- ☑ Ensure clearance requirements are strictly enforced around the batteries.
- ☑ Ensure the area around the batteries is well ventilated and clean of debris.
- ☑ Always use insulated tools. Avoid dropping tools onto batteries or other electrical parts.
- ☑ If a battery must be removed, always remove the grounded terminal from the battery first. Make sure all devices are disconnected.
- ☑ All devices must be disconnected when update the BMS software.
- ☑ DO NOT short the battery terminals.
- ☑ DO NOT incinerate, crush, or disassemble.
- ☑ DO NOT reverse connections (polarity) from charger to battery.
- ☑ DO NOT operate battery beyond published voltage and current limits.



IMPORTANT

- ☑ When installing batteries, leave adequate clearance between batteries.
- ☑ When replacing batteries, use the same part number of batteries.
- ☑ Avoid any fall or collision during the installation process.
- ☑ Do not remove the battery components. The maintenance of the battery should be carried out by a professional engineer.
- ☑ Do not expose the Li-ion battery to heat in excess of 55°C during operation, 60 °C in storage;
- ☑ The SOC is 50% when shipped from factory, it needs to be recharged in time for long time storage.

LOW VOLTAGE RESS BATTERY

This series li-ion batteries are designed for the residential energy storage market (RESS) which combines safe and reliable LiFePO4 prismatic cells with RESS dedicated BMS to guarantee high reliability, safety, and scalability when used with different inverter.

This series include 5 models configuration to adapt to the different capacity inverter.

- 51.2V100Ah (5.12KWH) ,
- 51.2V200Ah (100A 10KWH),
- 51.2V200Ah (150A 10KWH),
- 51.2V200Ah (200A 10KWH),
- 51.2V280Ah (140A 15KWH)

This document is intended for use by anyone required to install and operate Ritar rack type Li-ion batteries. Be sure to review this manual carefully to identify any potential safety risks before proceeding.

The owner must be familiar with all the features of this product before proceeding.

Failure to install or use this product as instructed can result in damage to the product that may not be covered under the limited warranty.

Product Introduction

The RESS batteries are shown in below figures.

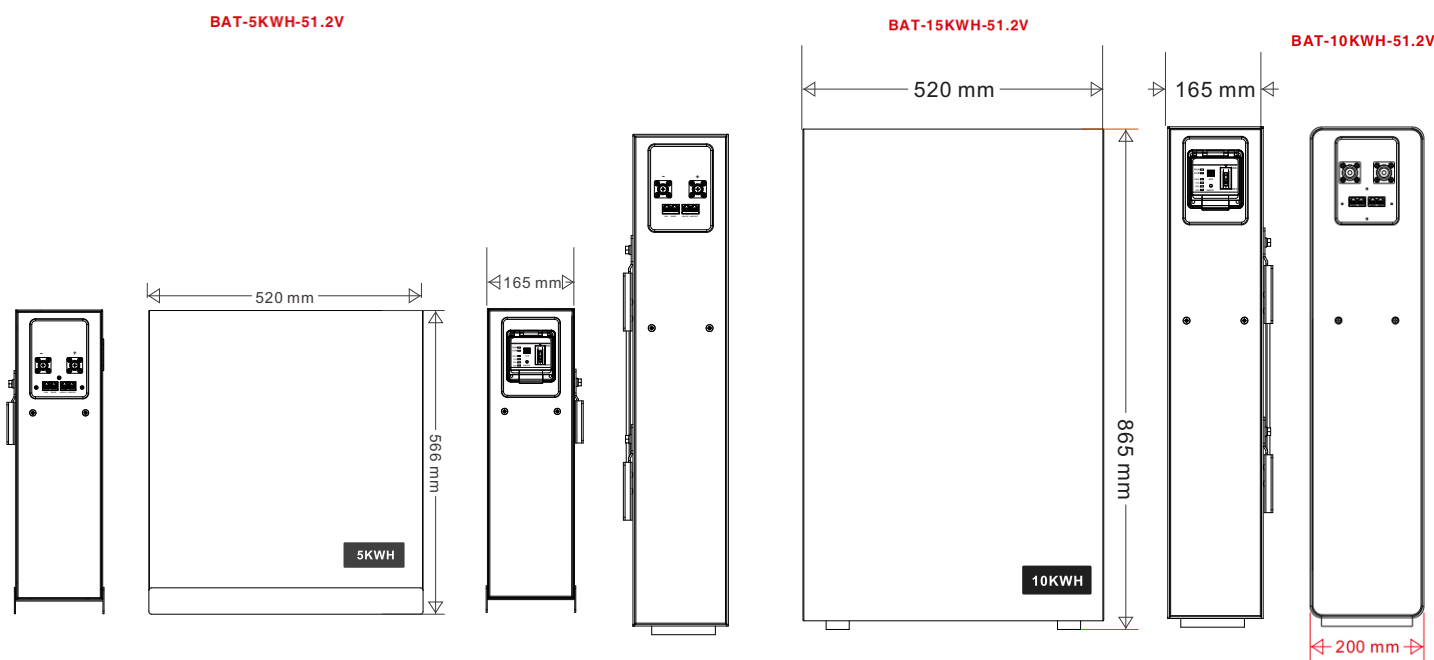

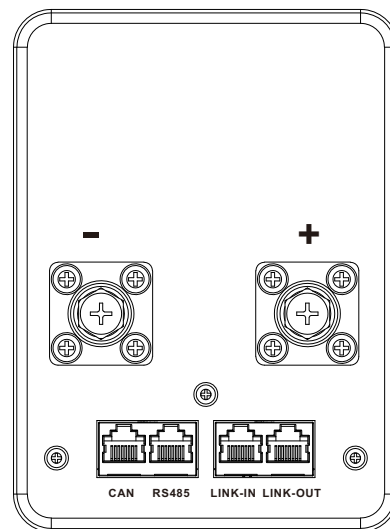
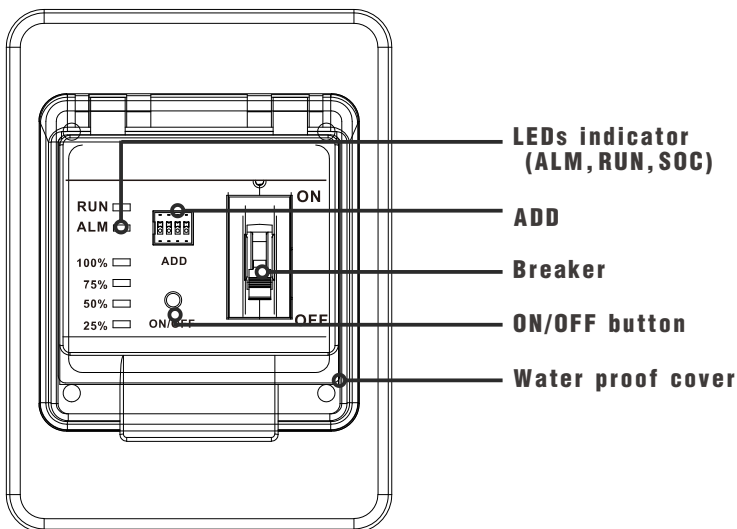

Communication port

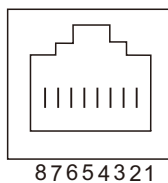

RS485 PIN MAP

RJ45 PIN	Description
1	RS485_B
2	RS485_A
3,4,5,6,7,8	NC

CAN PIN MAP

RJ45 PIN	Description
1,2,3,4,5,6	NC
7	CAN_H
8	CAN_L

LINK-IN/OUT PIN MAP







RJ45 PIN	Description
1,2,3,4,5,6	NC
7	RS485-2_A
8	RS485-2_B

ADD Switch



ADD	1#	2#	3#	4#	Remark
0	OFF	OFF	OFF	OFF	Pack 0
1	ON	OFF	OFF	OFF	Pack 1 Master Battery
2	OFF	ON	OFF	OFF	Pack 2
3	ON	ON	OFF	OFF	Pack 3
4	OFF	OFF	ON	OFF	Pack 4
5	ON	OFF	ON	OFF	Pack 5
6	OFF	ON	ON	OFF	Pack 6
7	ON	ON	ON	OFF	Pack 7
8	OFF	OFF	OFF	ON	Pack 8
9	ON	OFF	OFF	ON	Pack 9
10	OFF	ON	OFF	ON	Pack 10
11	ON	ON	OFF	ON	Pack 11
12	OFF	OFF	ON	ON	Pack 12
13	ON	OFF	ON	ON	Pack 13
14	OFF	ON	ON	ON	Pack 14
15	ON	ON	ON	ON	Pack 15

LED Indicator Description

Status	Nominal Warning Protection	RUN	ALM	SOC				Description
								
Shut down	Dormancy	OFF	OFF	OFF	OFF	OFF	OFF	
Standby	Nominal	Flash 1	OFF	Follow module capacity				Standby
	Warning	Flash 1	Flash 3	Follow module capacity				Module at low voltage
Charge	Nominal	ON	OFF	Follow module capacity				
	Warning	ON	Flash 3	Follow module capacity				
	Over-charge Protection	ON	OFF	ON	ON	ON	ON	LED turn to standby if no power supply
	Temperature, over-current, Failure protection	OFF	ON	OFF	OFF	OFF	OFF	Stop charging
Discharge	Nominal	Flash 3	OFF	Follow module capacity				
	Warning	Flash 3	Flash 3	Follow module capacity				
	Under voltage Protection	OFF	OFF	OFF	OFF	OFF	OFF	Stop discharging
	Temperature, over-current, short circuit, failure protection	OFF	ON	OFF	OFF	OFF	OFF	Stop discharging
Failure		OFF	ON	OFF	OFF	OFF	OFF	Stop charging and discharging

Note:

Flash 1: light 0.25s/off 3.75s

Flash 2: light 0.5s/ off 0.5s

Flash 3: light 0.5s / off 1.5s

ON/OFF Button

OFF mode

During in transport, BMS ON/OFF button is at OFF status. it will turn off the BMS power supply.

ON mode

By press ON/OFF button to active BMS to enter into working mode, if the MCB is also ON, the battery voltage will can be measured by terminal.

Even if the button is at ON mode, The BMS will enter into dormancy mode after 24 hours when there are no charge, no discharge and no communication. it can be activated again by charge or communication or repress ON/OFF button.

History Record

The BMS can restore 500 logs about historical alarm / protection data, the logs can be read by PC software.

Parameters

Model	BAT-5KWH-51.2V	BAT-10KWH-51.2V -100A	BAT-10KWH-51.2V -150A	BAT-10KWH-51.2V -200A	BAT-15KWH-51.2V -140A
Nominal Voltage [V]	51.2	51.2	51.2	51.2	51.2
Nominal Capacity [Ah]	100	200	200	200	280
Total Energy [Wh]	5120	10240	10240	10240	14336
Dimension (W*D*H, mm)	520*165*566	520*165*865	520*165*865	520*165*865	520*200*865
Weight [Kg]	50	96	96	96	125
Max. Charging Current [A]	100	100	150	200	140
Max. Discharging Current [A]	100	100	150	200	140
Pulse Discharge Current	110A @10min 120A @10s	110A @10min 120A @10s	165A @10min 180A @10s	210A @10min 220A @10s	165A @10min 180A @10s
Charging Voltage [V]	55.2~57.6				
End of Discharge Voltage [V]	44.8 (Backup Application) / 48 (Cycle Application)				
Operation Humidity	0~95% RH (No condensing)				
Operating Temperature Range	Standard Product: Charge: 0 ~ +55°C; Discharge: -20 ~ +55°C With Optional Heater: Charge / Discharge: -30 ~ +55°C				
Cycle Life ⁽¹⁾	>6000				
Designed Calendar Life	10 Years				
Communication interface	RS485, CAN				
Protection	Over voltage , Low voltage, Over current, Over Temperature, Low Temperature, Short circuit				
Parallel Support ⁽²⁾	Yes, Max. 15 Sets				
Series Support	Not support				

Note:

(1) 25°C ,0.5C/0.5C, 90%DOD and 70% EOL

(2) For parallel connection, refer to user manual.

TRANSPORTATION AND STORAGE

Transportation requirement

The product passes the certifications of the UN38.3 (UN38.3: Section 38.3 of the sixth Revised Edition of the Recommendations on the Transport of Dangerous Goods, Manual of Tests and Criteria) and SN/T 0370.2-2009 (Part 2: Performance Test of the Rules for the Inspection of Packaging for Exporting Dangerous Goods). This product belongs to class 9 dangerous goods.

The SOC is 50% when shipped from factory.

The product can be delivered to the site directly and transported by land and water. The packing case must be secured for transportation, compliant with related national standards,

and printed with marks such as anti-collision and moisture prevention. Dispose of waste ESMS in strict accordance with local laws and regulations.

Protect the packing case with the product from the following situations:

- Being dampened by rains, snows, or falling into water
- Falling or mechanical impact
- Being upside-down or tilted

Storage

The rack type Li-ion battery can be stored in an environment with temperatures between -40°C and $+60^{\circ}\text{C}$ and between 10% and 90% relative humidity, non-condensing. For long storage periods at 25°C , charge the battery every 6 months. For temperatures above 40°C , charge the battery every quarter.

Do not store the Li-ion battery at temperatures above 60°C .

Keep away from heat sources (such as a heater)

Communication with different inverter

Ritar RESS li-ion battery BMS support to do communication with below inverters.

This chapter mainly introduce the communication cable connection and BMS software configuration.

SN	Inverter Brand	Adaption Series	Communication
1	Victron	CCGX- VE-CAN	CAN
2	SMA	SUNNY ISLAND Series	CAN
3	Megarevo	REVO Series	CAN
8	MUST	Solar Inverter 2KW-5.5KW	CAN
4	Voltronic	Axpert Series	RS485
5	Growatt	SPF *** TL, ES, Series.	RS485
6	OPTI	SP5000 Handy Plus	RS485
7	DEYE	SUN-3K/3.6K-SG04LP1	RS485
9	INHENERGY	HI-**-SL Series	RS485
10	Afore	HNS3000-6000HS	RS485
11	Phocos	Any-Grid PSW-H	RS485

Note: The list of inverter will renew by the BMS software update, the newest inverter list will shown on BMS PC software.

Communication cable

The accessories communication cable is standard T-568B CAT5-e cable. it can be used for battery-battery internal communication and inverter CAN (Victron), RS485 (Growatt, DEYE, INHENERGY), for other brand inverter, it needs to modify communication cable according to PINOUT of inverter.

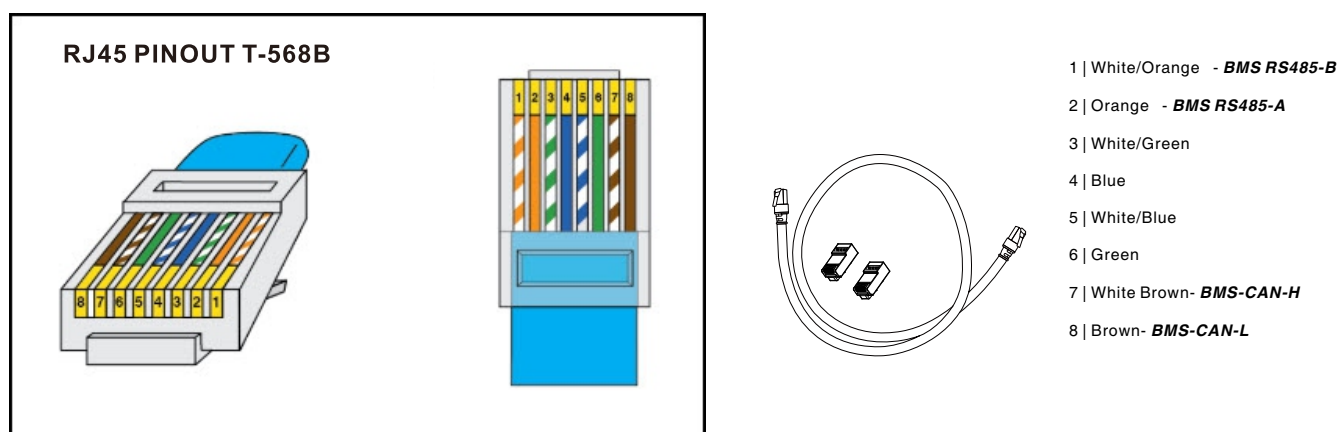

BMS RS485 and CAN Port, Major inverter BMS Port.

PIN	BMS		CAN				RS485					
	RS485	CAN	Victron	SMA	Megarevo	MUST	Growatt	Voltronic	DEYE	Afore	Phocos	INHENERGY
1	485_B	NC	NET-C/V-	Sync1-reserved	/	485_B	485_B	/	485_B	Meter 485A	232_RX	485_B
2	485_A	NC	NET-S/V+	CAN_GND	/	485_A	485_A	/	485_A	Meter 485B	232_TX	485_A
3	NC	NC	NET-C/V-	SYNC_H	/	GND	NC	485_B	/	BAT 485A	485_B	GND_S
4	NC	NC	NC	CAN_H	CAN_H	/	NC	/	CAN_H	BAT CANH	+12Vdc	CAN_H
5	NC	NC	NC	CAN_L	CAN_L	CAN_L	NC	485_A	CAN_L	BAT CANL	485_A	CAN_L
6	NC	NC	NET-S/V+	SYNC_L	485_GND	CAN_H	NC	/	485_GND	BAT 485B	CAN_H	NTC.BAT
7	NC	CAN-H	CAN-H	Sync7-Reserved	485_A	/	NC	/	485_A	CTU	CAN_L	WAKE-
8	NC	CAN-L	CAN-L	Sync8-Reserved	485_B	/	NC	/	485_B	CTN	GND	WAKE+

System cable connection

- Step 1. Make sure the battery breaker is in off condition. Connect the power cable to inverter. Make sure the screws are tight.
- Step 2. Connect the communication cable.
- Step 3. Set the battery module ID by ADD. **The master battery which do communication with inverter ADD must be 1.**
- Step 4. Make sure the inverter had be installed correctly.
- Step 5. Press ON/OFF button to activate the battery BMS and connect battery to PC by BMS PC software, select inverter protocol on BMS (detail operation refer to user manual)
- Step 6. Turn on battery breaker and the inverter will be activated, set the inverter (battery type and protocol).
- Step 7. If the communication between BMS and inverter is nominal, the SOC, temperature information in PC and inverter display will be totally same.
- Step 8. **Charge the batteries fully in first use.**

Note:

- For 1pcs 5KWH battery and 10KWH-100A , it max support 5KVA inverter or the real load power consumption is less than 5KW.
- For 1pcs 10KWH-150A battery , it max support 8KVA inverter or the real load power consumption is less than 7KW.
- For 1pcs 10KWH-200A battery , it max support 10KVA inverter or the real load power consumption is less than 8KW.
- For 1pcs 15KWH-140A battery , it max support 8KVA inverter or the real load power consumption is less than 8KW.

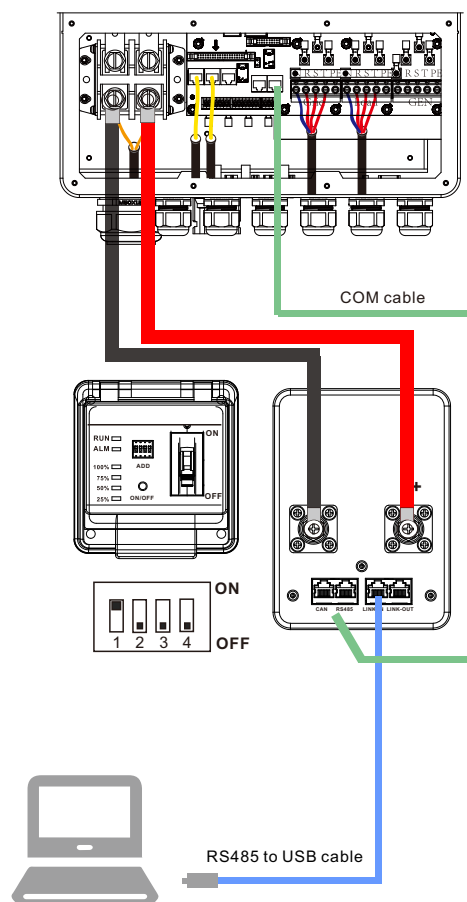

Charging Batteries

The constant current (CC) charger is recommended strongly.

The charge voltage and current setting can refer to below table:

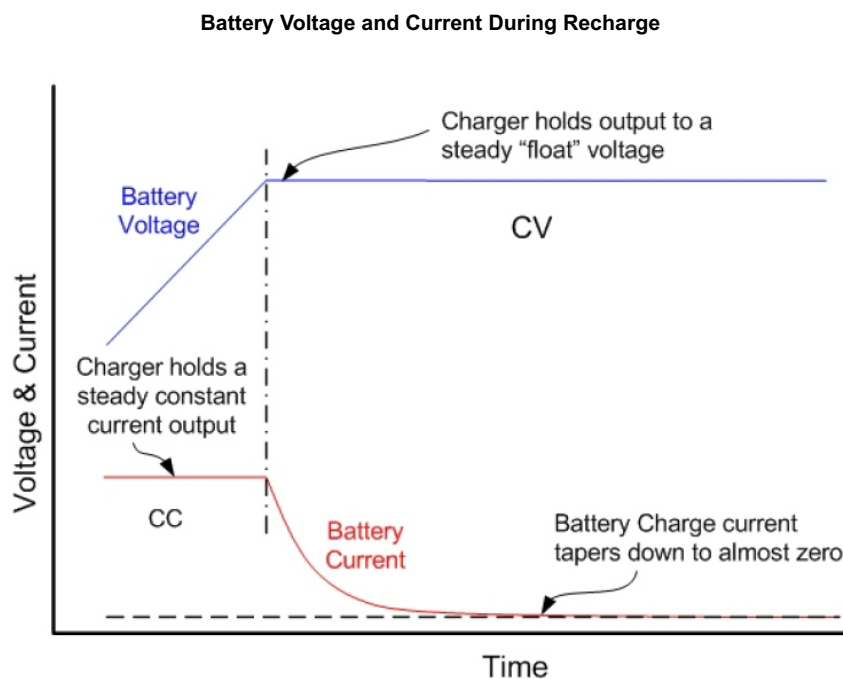

- If there are communication between battery and inverter, the BMS will automatic request charge and discharge parameters from inverter,
- If there are no communication between battery and inverter, setting charge and discharge parameters on inverter.

Recommended setting for 51.2V battery:

Equalized charging voltage: 56.0Vd

Float charging voltage: 53.9Vdc

Charge current: 0.5C

End of discharge voltage: 48Vdc

BMS PC Software Operation

1. Download BMS PC software and Unzip to a local folder.

http://120.27.63.138:8181/attach_files/rack_telecom/6

2. Connect battery LINK-IN port to computer by RS485 to USB equipment:

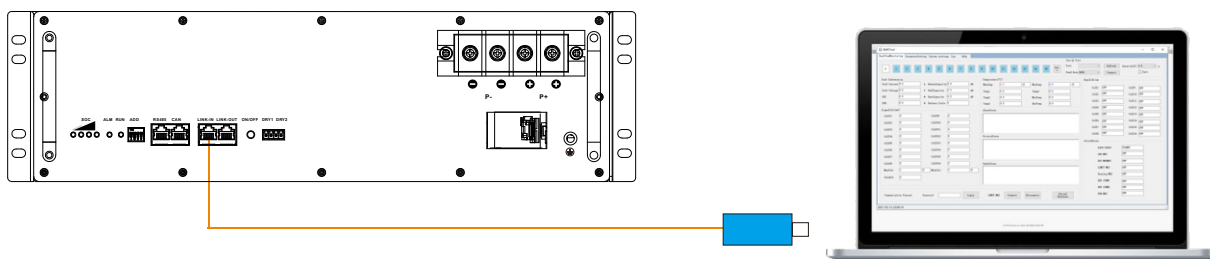

3. Check the battery ADD and make sure the ID=1



4. Double click “BMSTool.exe” to run BMS PC software.

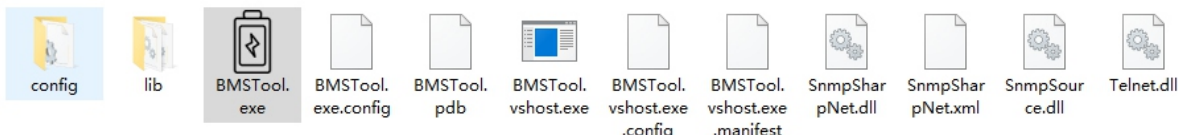

If RS485 to USB device is connected well, the serial port will be listed, otherwise, it needs to install USB driver.

Battery ADD

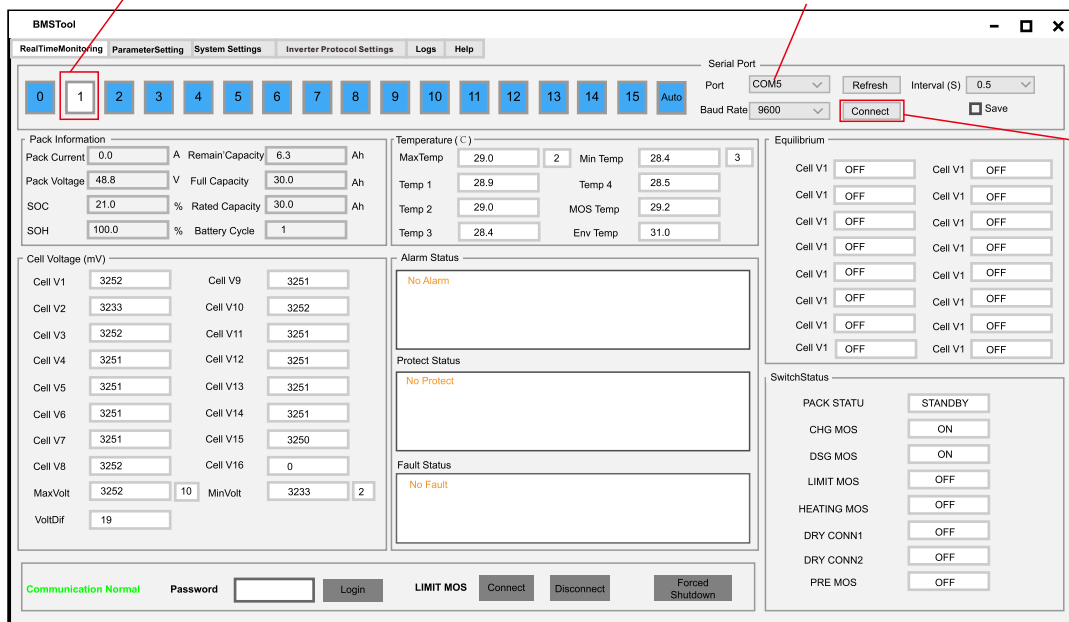

3. Click “Connect”, the BMS detail information will be listed

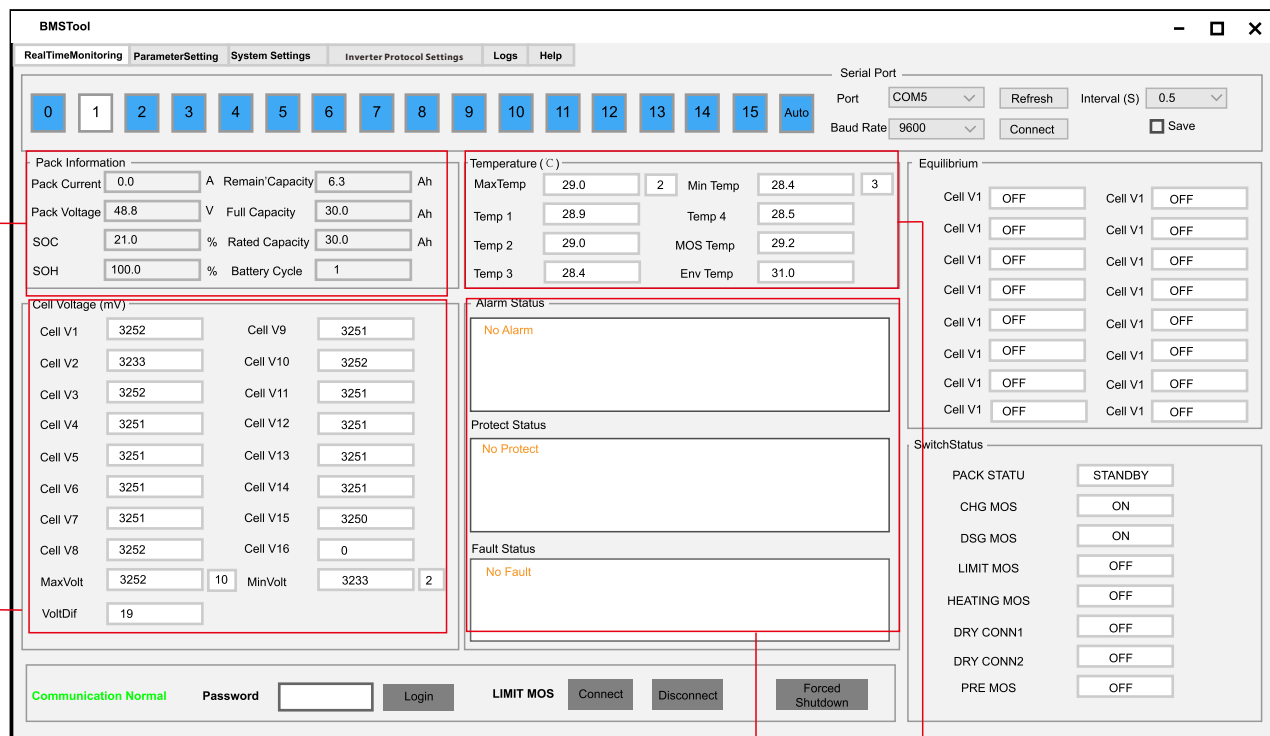

The screenshot shows the BMSTool interface with several key sections highlighted by red boxes:

- Pack Information:** Displays Pack Current (0.0 A), Pack Voltage (48.8 V), SOC (21.0%), SOH (100.0%), and Battery Cycle (1).
- Temperature (C):** Shows MaxTemp (29.0), Min Temp (28.4), and individual temperatures for Temp 1-4 and MOS Temp (29.2).
- Cell Voltage (mV):** Lists voltages for 16 individual cells (V1-V16) and MaxVolt (3252 mV).
- Alarm Status:** Shows 'No Alarm', 'No Protect', and 'No Fault'.
- SwitchStatus:** Includes controls for PACK STATUS (STANDBY), CHG MOS, DSG MOS, LIMIT MOS, HEATING MOS, DRY CONN1, DRY CONN2, and PRE MOS.

Battery information:
Total current, Total voltage,
SOC, SOH, Remain capacity,
Rated capacity, Cycle times.

Cells information:
Cell voltage

Alarm, Protection, Fault
information

Temperature information:
Cell temperature
Environment temperature
BMS temperature (MOS)

Note:

The Parameter setting change must be carried out by a professional engineer.

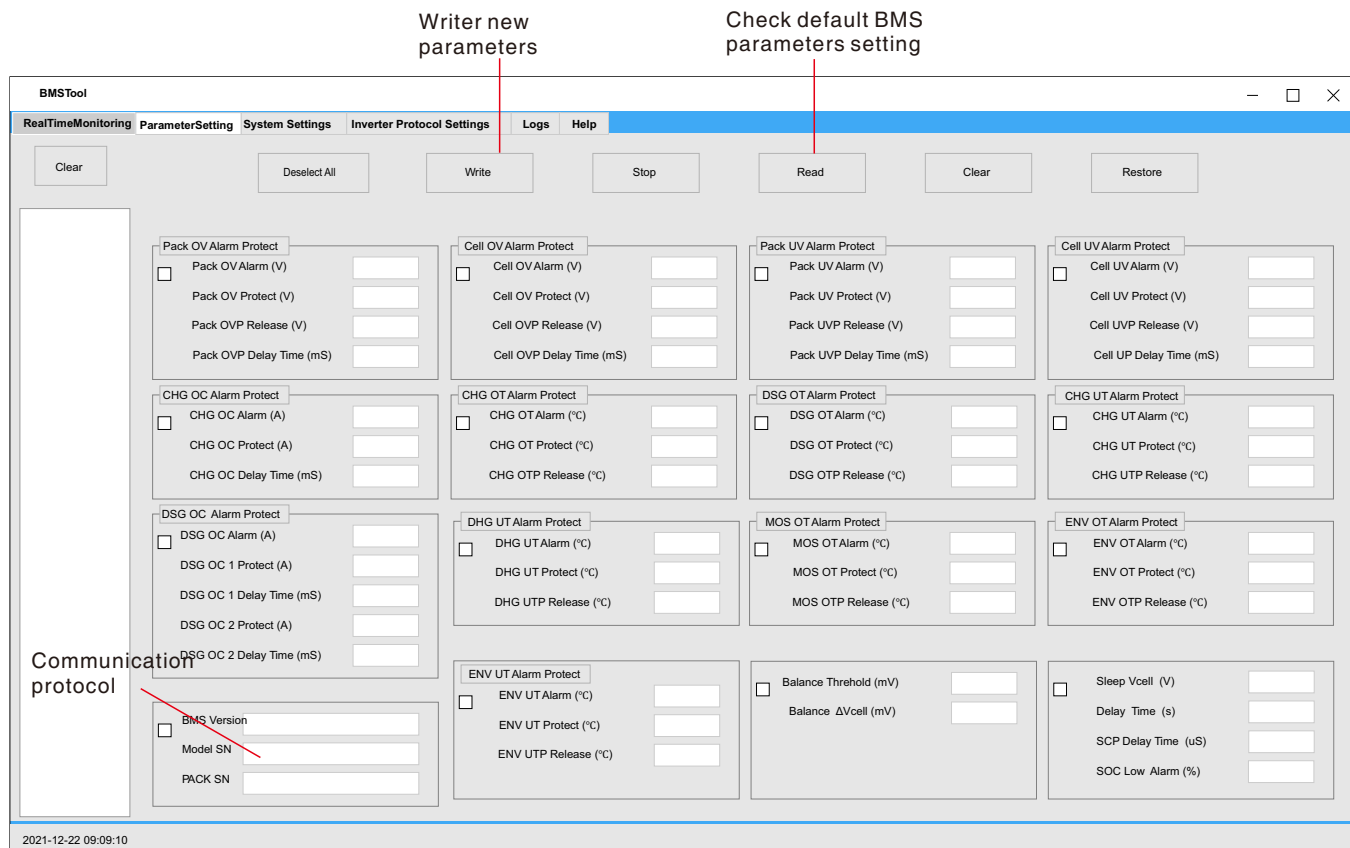

The screenshot shows the ParameterSetting tab in BMSTool. Annotations include:

- Writer new parameters:** Points to the 'Write' button.
- Check default BMS parameters setting:** Points to the 'Read' button.
- Communication protocol:** Points to the 'BMS Version', 'Model SN', and 'PACK SN' fields.

The interface contains numerous parameter settings for various protection and alarm functions, such as Pack OV Alarm, Cell OV Alarm, Pack UV Alarm, Cell UV Alarm, CHG OC Alarm, CHG OT Alarm, DSG OC Alarm, DHG UT Alarm, MOS OT Alarm, ENV UT Alarm, Balance Threshold, and Sleep Vcell.

- Click “ Read” to check currently loaded communication protocols.
- Select protocol by inverter brand and click “Write” to reload protocol.
- Click “ Read” to check

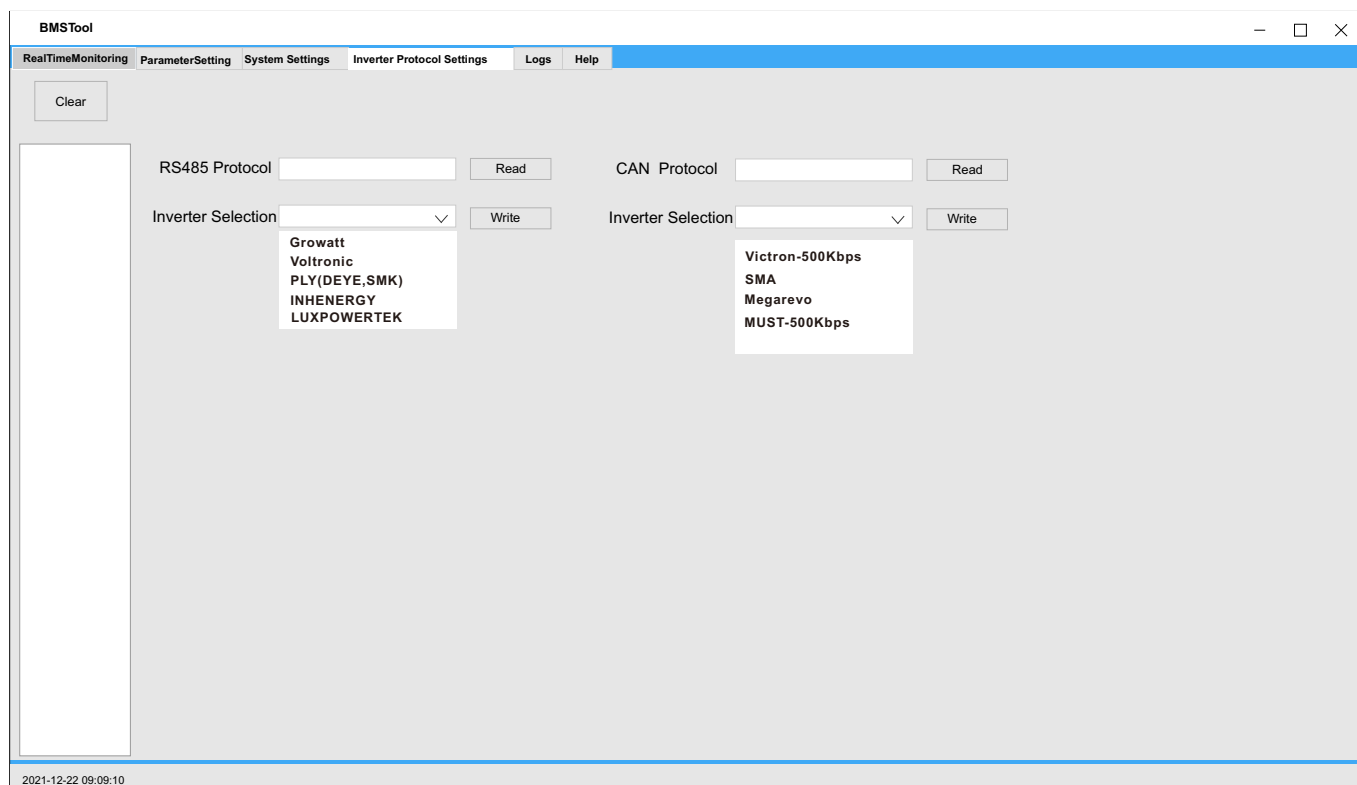

Annex A: Parallel Connection With Distribution BOX

Distribution box is optional for the situation which parallel over 3 batteries or 2~3 inverter in parallel.

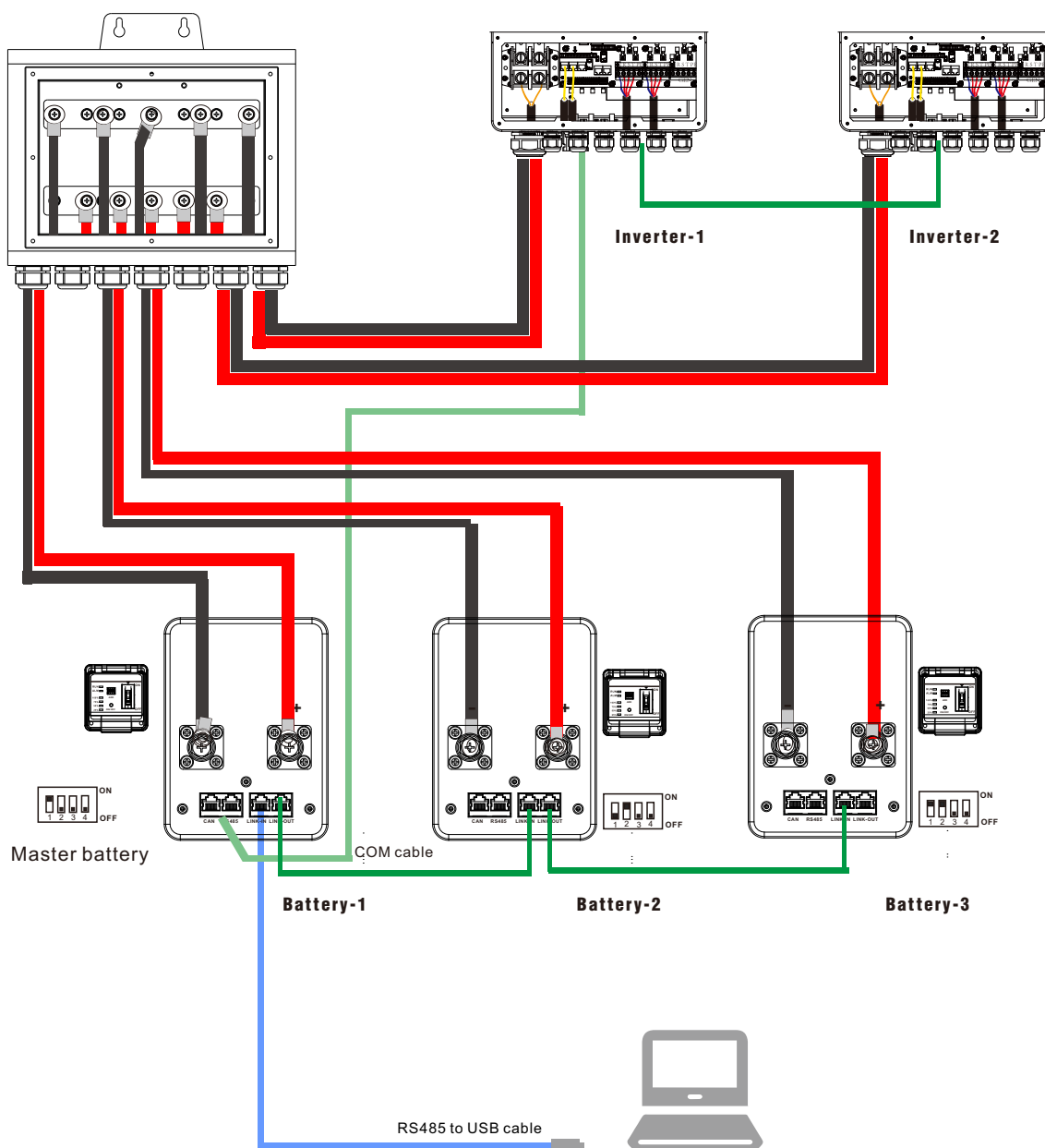

Note:

- ☑ Ensure the cables are properly sized.
- ☑ The length of cables should be same.